

# The Painless Parafoil

By Hugh R. D. (Stretch) Tucker



HOW DOES IT FLY? WELL, IT LEANS FORWARD UNTIL IT JUST LOSES ITS BALANCE, AND AS IT FALLS OFF THE BRANCH, IT FLAPS A COUPLE OF TIMES UNTIL IT FILLS WITH AIR, AND THEN IT SOARS ALOFT AS QUICKLY AS YOU AND THE WIND WILL LET IT.

**A**t the Maryland Kite Society's winter kite retreat weekend in February, a late-night group was talking about parafoils. Bill Tyrrell said that many people are cautious about building a parafoil because a lot of emphasis is placed on the back curve of the rib profile. What we need is a parafoil with straight lines.

Next morning I drew up this design. It incorporates several ideas to help take the fear out of parafoils. For example:

- a) length of ribs is set to match the width of a roll of fabric (41 inches);
- b) one-piece keels avoid alignment necessary with triangular flares;
- c) small size—15 square feet—is not intimidating and is a workable size for experimenting with other options.

If you follow these instructions, you should not have any problems. Just realize a couple of things at the beginning:

- a) all seams are flat, and alignment is made on the leading edges of ribs, keels, back and face panels;
- b) the seams of the two outer ribs are on the *outside* of the kite;
- c) at no time is the sewing machine *inside* the kite—unless you read instructions as a last resort when all else fails. Then you may have to use a pair of scissors.

## Tools

- pen or pencil
- hot knife
- straightedge

- sharp knife (razor) or scissors
- sewing machine

## Materials

- 2 pieces of cardboard for templates, one about 6" x 40" for ribs and the other about 6" x 36" for keels
- 2 pieces of ripstop nylon, 61" x 41" (width of fabric), one piece for the back panel and the other for the face panel
- 2 pieces of ripstop nylon 120" x 41" for ribs and keels
- 66" x ¼" webbing or heavy ribbon to make bridle loops and trailing edge tabs
- 85 feet of 100-pound Dacron polyester line for bridles.

## Cutting

First, cut the two cardboard templates for the ribs and keels. The dimensions given (*diagram 1*) represent the finished size, so add your hem allowance. I usually add ½ inch to allow for a double-fold ¼-inch hem.

Lay out the templates on the fabric for best economy. The ribs will all run parallel, one next to the other, but the keels can be staggered (*diagram 2*). You will need 11 ribs and 6 keels.

Cut back and face panels to length (60 inches plus ½ inch each end). Be sure cuts are parallel, and at right angles to the side chosen as the leading edge.

All the above cuts can be made with a straightedge and a razor knife (no hot knife needed), because the exposed edges

will end up inside the hems.

With a hot knife, make cross-vent holes (2½" diameter) in nine *only* of the ribs. Save two ribs without holes for the outer panels.

Also with the hot knife, cut 66 inches of tape/webbing into twelve 5-inch lengths for bridle loops and three 2-inch lengths for trailing edge (tail) loops.

## Layout

On the back and face panels, draw a series of rib lines on 6 inch spacing (*diagram 3*). The outside lines (½ inch from the edge) are the hem lines. Make sure that these lines are parallel to each other and at right angles to the leading edge. These will be the stitch lines for the ribs

Turn face panel over and draw keel lines on 12-inch spacing, that is, on every other rib line.

## Sewing

Take a deep breath! Let it out! Repeat several times! Now, read this part through all the way so you'll have some idea of the sequence of steps.

**1.** Fold and sew a ¼-inch double hem on (a) the leading edge and sides of the back panel, (b) the leading edge and sides of the face panel, and (c) all edges of the ribs. *Note:* Lay one outside rib on its opposite face when hemming, so that its hems will be inside the kite.

**2.** Fold and sew a ¼-inch double hem

Diagram 1. TEMPLATES

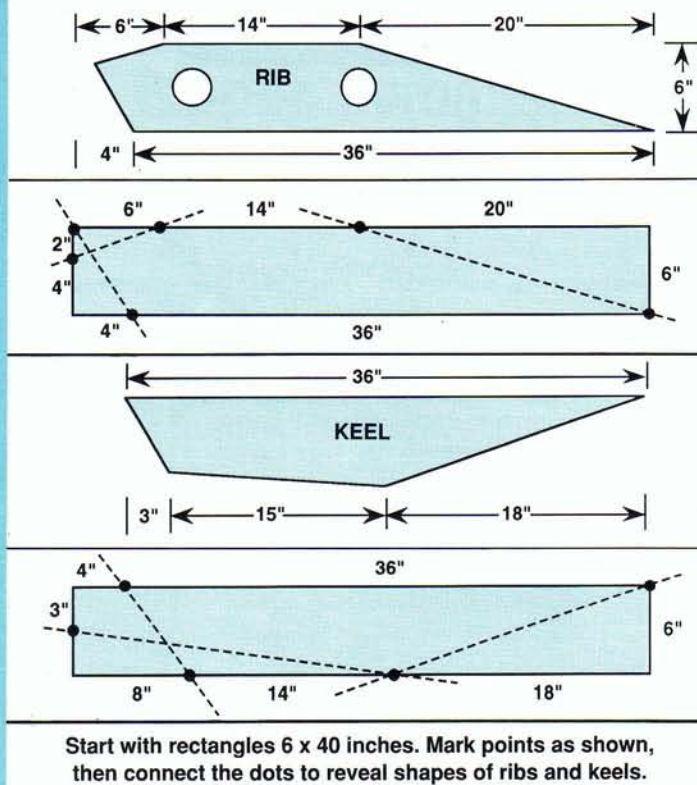

on all edges of the keels, but lay them in alternate directions, so you have three left-handed and three right-handed keels.

3. Fold and sew a 5-inch length of tape or webbing on each keel at the points marked. Sew the loops on the same side of the keel as the hems.

4. Flip the back panel so that its hems are facing up (rib lines showing). Starting with the left side, take one of the ribs *without holes* and sew the back of the rib to the edge of the panel. The hems of the rib will face *in*, toward the panel. The hem of the rib and the hem of the panel are sewn face-to-face. Be sure to use the correct ribs—left or right—on the outer edges of the panels.

Proceed across the panel, left to right, and sew the remaining ribs down the lines on 6-inch intervals. The two end ribs will have their hems facing in toward the center of the kite (*diagram 4*).

5. Lay the face panel on its back (the inner surface), with its hems *down*. Starting at the left edge, sew the keels onto the face panel on the 12-inch spaced lines. Three keels face right and three keels face left towards the center line (*diagram 4*).

6. Lay the back panel on its back, ribs uppermost. Lay the face panel on its face, keels underneath. Both leading edges will face away from you, back panel on the left.

Sew the outside rib on the right edge of the back panel to the left edge of the face panel. At this point, you may have to roll up the face panel and keels to make them fit through the throat of the machine.

Pulling each rib over from the left with the back panel, sew progressively across the face panel along the 6-inch spacing lines.

Remember to fold each keel out of the way after you have sewn a rib along its line. Ribs and keels are sewn along the same line.

After you sew the last outside rib onto the face panel, you will have an almost complete kite on the left side of the sewing machine, facing away from you.

7. All that remains now is to clean up the trailing edge. Notice the face panel has about 4-5 inches of extra fabric beyond the ribs and keels, while the back panel has about 1½ inches.

Lay the kite face down on a flat surface, leading edge away from you. Fold the keels under so they lie flat, and smooth out the kite as best you can. With a hot knife and a straight-edge, trim both back and face panels together, leaving about 1½ inches beyond the keels and ribs. In other words, trim off the excess fabric of the trailing edge of the face panel to match the trailing edge of the back panel.

You can finish the trailing edge in several ways:

a) With the trailing edge stuck together from the hot knife, just double fold over and sew a ¼-inch hem the entire width of the kite. Add tape loops in the center and corners of the trailing edge.

b) Carefully separate the two panels at the trailing edge, double fold each inward (toward inside of kite) and sew a ¼-inch hem on each panel. Then sew both hems together, adding a folded two-inch length of tape as a loop in

Diagram 2. CUTTING LAYOUTS

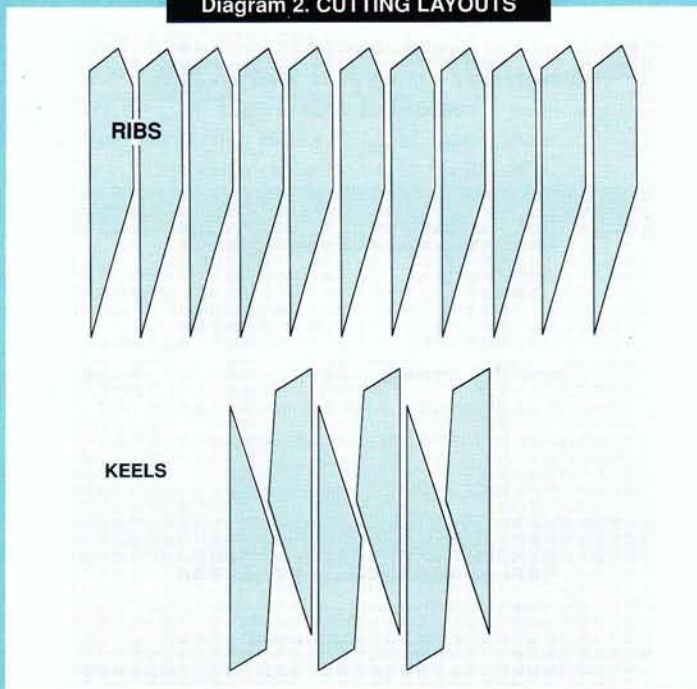
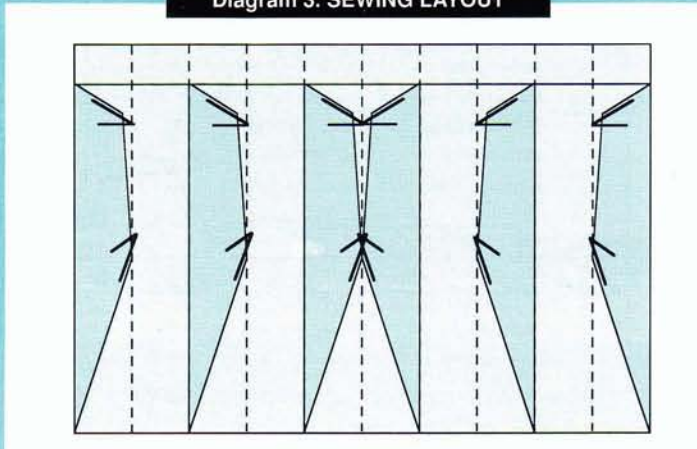

Diagram 3. SEWING LAYOUT



the center and at both corners of the trailing edge.

c) Sew separate hems as in b) above, but when you sew them together, leave the center inch or two of each cell open to allow air to vent through the trailing edge. Add tape loops in the center and corners of the trailing edge.

## Bridling

You remember that 85 feet of line? Well, cut off 12 inches and set it aside. Take the remaining 84 feet and cut it into six equal 14-foot lengths.

Take three lengths, fold them in half and tie an overhand knot, giving you a loop and six legs, as shown below.

Take two of the six legs and attach them to the front loops of the outside keels. Make both legs equal in length, measuring from the point of the keel. (There may be variations in loop length!)

Pick another two bridle lines and tie them onto the front loops of the next two keels. These lines will be three inches shorter than the outside pair, and should be equal in length to each other.

The third pair of bridle lines is tied onto the front loops of the two center keels. These will be two inches shorter than the previous pair, and equal in length to each other.

Repeat this entire process with the three remaining 14-foot lengths, tying them onto the rear loops of the keels. The measurements are the same as the front bridle lines.

What you are aiming for is a kite with a flat base, and with bridle lines which are symmetrical around the centerline.

Diagram 4. SEWING ORDER

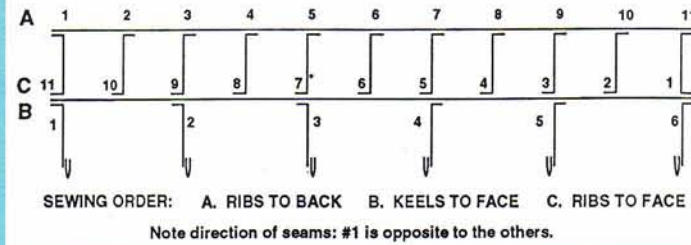

Detail: KEEL POINTS

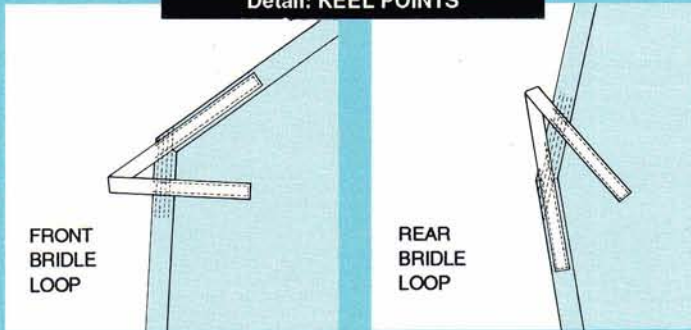

Detail: BRIDLE SECTIONING

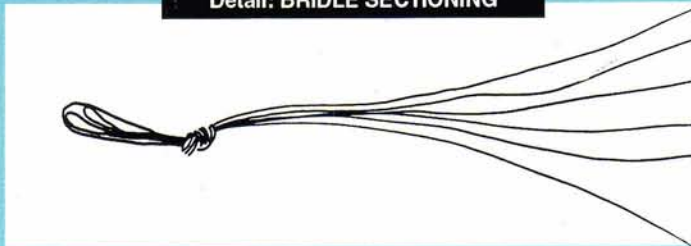

Detail: DOUBLE SHEETBEND KNOT

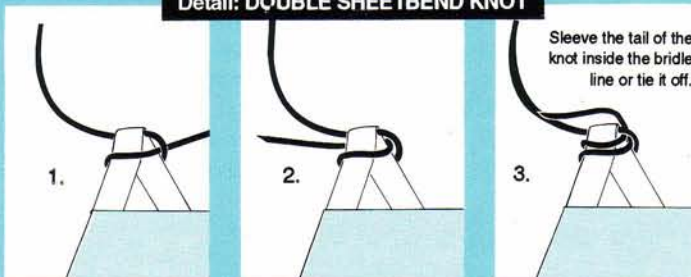

Detail: OPTIONAL DROGUE

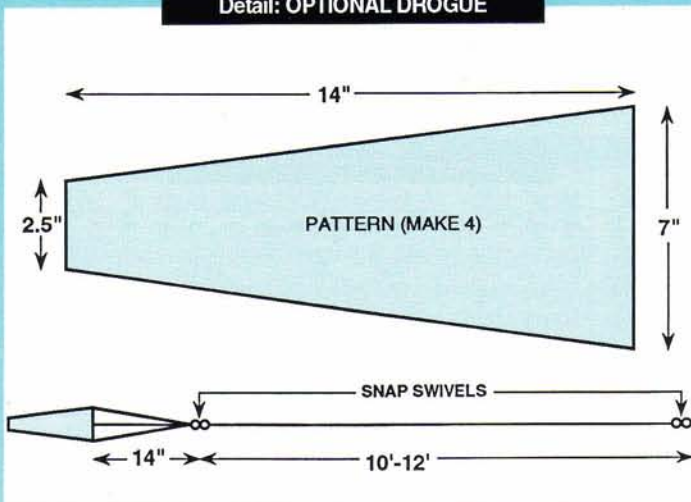

DRAWINGS NOT TO SCALE, BY THE KITE LINES STAFF

The 12 inches of line left over? Use it to join the loop of the front bridles to the loop of the rear bridles. Put a sturdy metal ring onto this length of line with a lark's head knot. This will give you a two-leg bridle with easy adjustment for varying wind conditions.

Once you have found a good median tow point, your adjustments should be about 1/4-1/2 inch from that point. Move the ring forward (toward leading edge) for light air, backward (away from leading edge) for strong winds.

Does it need a drogue? No, but if you want to put one on—go for it! Hang it 10-12 feet behind the kite.

## Watch Your Step

Let me guess—you got to Step 17, realized that the sewing machine was stuck in the middle of everything and would not come out. Well, call Doug Hagaman or George Ham or Bill Tyrrell, and if they can help, let me know because I'd like to know where you found Step 17.

In any case, whatever you choose to do with or to these plans, you will have the satisfaction of knowing that you have built a real parafoil and it was painless—well, practically painless.

## For the Future

If you want to make a scaled-up version of this parafoil, remember that as you increase the size of the ribs you'll need *more of them*. However, variations of all kinds are worth trying. Dom Jalbert gave us the parafoil, but he didn't close the book on it. Everything we do adds to the opus. ◇